



BUILDING DEPARTMENT
 VILLAGE OF GREENPORT
 236 Third Street, Greenport, NY 11944

HISTORIC PRESERVATION COMMISSION REVIEW

APPLICATION FOR CERTIFICATE OF APPROPRIATENESS

PURSUANT TO THE PROVISIONS OF CHAPTER 48
 HISTORIC PRESERVATION LAW OF THE VILLAGE OF GREENPORT

DATE OF APPLICATION: February 4, 2025

LOCATION OF PROPERTY: 102 BROAD ST NW CORNER of 1st St

SUFFOLK COUNTY TAX MAP NUMBER: 1001-2-5-29

PROPERTY OWNER: CYNTHIA A. ROE

ADDRESS: 102 BROAD ST PHONE: 646- [REDACTED]

EMAIL ADDRESS: [REDACTED]@gmail.com

ARCHITECT/DESIGNER: Soter & Soter

ADDRESS: P.O. Box [REDACTED] Cutchoque 11935 PHONE [REDACTED]

EMAIL ADDRESS: soter and soter@gmail.com

Type of Proposed Work

COMMERCIAL RESIDENTIAL

Site Work

- ___ FENCE AND GATES
- ___ DRIVEWAY, WALK, PATIO, OTHER PAVEMENT
- ___ MAJOR EXCAVATION OR REGRADING, OR BERM
- ___ SWIMMING POOL, TENNIS COURT
- ___ OTHER STRUCTURAL LANDSCAPE ELEMENT
- ___ SIGNAGE AND AWNINGS - SUBMIT SCALE DRAWINGS TO INDICATING TO FOLLOWING:
 - SIZE OF EACH SIGN
 - COLOR
 - FONT
 - LOCATIONS OF ALL SIGNAGE AND AWNINGS ON BUILDING
 - PROPOSED MATERIALS
- ___ MODERN FEATURES
 - SOLAR PANELS
 - SKYLIGHTS
 - OUTDOOR SHOWERS
 - OTHER

Landscape Planting

- ___ HEDGE ALONG STREET AND/OR PROPERTY BOUNDARY LINES
- ___ PLANTINGS INTENDED TO SCREEN OTHER WORK DESCRIBED IN THIS APPLICATION

Buildings

- NEW CONSTRUCTION
- ADDITION
- DEMOLITION
- REMOVAL
- ACCESSORY BUILDING

Building Alterations

- EXTERIOR WALL MATERIAL
- ROOF MATERIAL AND COLOR
- CHIMNEY MATERIAL
- FOUNDATION MATERIAL
- DOORWAYS (INCLUDING STORM/SCREEN DOORS)
- WINDOWS (INCLUDING STORM/SCREEN SASH) AND SHUTTERS
- PORCHES AND STEPS
- TRIM AND DECORATIVE DETAIL
- GUTTERS AND LEADERS
- PAINT AND STAIN
- EXTERIOR LIGHTING
- OTHER

PROVIDE A GENERAL DESCRIPTION OF THE PROPOSED WORK (USE ADDITIONAL SHEETS IF NECESSARY, REFER TO THE ACCOMPANYING EXHIBITS).

★ ATTACHED

LIST ALL EXHIBITS SUBMITTED WITH THIS APPLICATION. ACTUAL SAMPLES OF MATERIALS AND/OR DESCRIPTIONS OF ACTUAL MATERIALS ARE REQUIRED. (REFER TO THE INSTRUCTIONS FOR THE REQUIRED SUBMISSIONS).

OTHER APPROVALS REQUIRED:

SIGNATURE OF OWNER OR AUTHORIZED AGENT:

DATE:

Cynthia [Signature]
Feb 4, 2025

★ General Description

Proposed first floor addition of 27 sq ft under the existing second floor overhang.

Moving existing entry steps on the rear deck .

North elevation , moving entry door and adding a window.

West elevation , replacing short double hung windows with longer double hung windows that match the existing and adding one additional window.

South elevation , adding an oval window under the porch.

East elevation , shortening the kitchen window and adding a balancing window next to it , and adding a window on the second floor.



CERTIFICATE OF APPROPRIATENESS (COA)

Historic Preservation Commission
Village of Greenport
236 Third Street, Greenport, NY 11944
631-477-0248
villageofgreenport.org

HISTORIC PRESERVATION COMMISSION APPROVAL

The Historic Preservation Commission hereby issues a Certificate of Appropriateness (COA) for the proposed work as it is in keeping with Chapter 76-6 of the Village of Greenport Code and specifically the six factors delineated in Chapter 76-6 (B). The COA for the proposed work is issued in accordance with the attached plans and any approval conditions, if attached hereto.

CONDITIONS OF APPROVAL FOR THE PROPERTY LOCATED AT:

APPROVED: As presented Subject to conditions below

PROJECT SPECIFIC CONDITIONS:

1. _____
2. _____
3. _____

Signature of Chair _____ Date _____

GENERAL CONDITIONS:

1. The person signing this form is responsible for communicating the Terms and Conditions listed herein to all contractors for the project.
2. Design, materials, and construction methods shall be as shown on the COA, either in the conditions or on the attached plans.
3. The COA approval is limited to the scope of work documented in the accepted plans with conditions of approval.
4. No visible or concealed structural elements or historic features may be modified or removed unless identified in the COA approval.

Note: If unforeseen issues arise during construction, or if a change to the project is being considered, work should be suspended, and an application for a review of the additional planned work must be submitted to the Historic Preservation Commission.

APPLICANT/AUTHORIZED AGENT SIGNATURE:

I agree that all work shall be in accordance with the plans, specifications and conditions which accompany this application, and I have read and understand the Historic Preservation COA General and Project Specific Conditions.

Signature *[Handwritten Signature]* Date *Feb 9, 2025*



Village of Greenport Building Department

236 Third Street, Greenport, New York, 11944

(631) 477-0248 Ext. 212

www.villageofgreenport.org

ASBESTOS CERTIFICATION FORM

Notice to Building Applicants:

AN ASBESTOS SURVEY IS REQUIRED FOR ALL RENOVATION, REMODELING, REPAIR AND DEMOLITION OF ALL INTERIOR AND EXTERIOR BUILDING MATERIALS.

AS PER NEW YORK STATE INDUSTRIAL CODE RULE 56, ASBESTOS MATERIAL MUST BE ABATED BY LICENSED CONTRACTORS UTILIZING CERTIFIED ASBESTOS HANDLERS, WITH THE EXCEPTION OF OWNER-OCCUPIED SINGLE-FAMILY HOMES, WHERE THE OWNER MAY REMOVE THE ASBESTOS AND RENOVATE THESE STRUCTURES THEMSELVES. IT IS NOT RECOMMENDED THAT THE OWNER PERFORM ABATEMENT, AS THE OWNER COULD POTENTIALLY EXPOSE THEMSELVES, THEIR FAMILY AND NEIGHBORS TO ASBESTOS FIBERS IF ADEQUATE ENGINEERING CONTROLS AND WORK METHODS ARE NOT UTILIZED DURING THE ABATEMENT.

FOR FURTHER INFORMATION AND UPDATES, PLEASE SEE THE NEW YORK STATE WEBSITE AT: WWW.LABOR.STATE.NY.US OR CONTACT THE ASBESTOS CONTROL BUREAU DISTRICT OFFICE, NYS DEPARTMENT OF LABOR, ASBESTOS CONTROL BUREAU, 75 VARICK STREET, 7TH FLOOR, NEW YORK, NY 10013, TELEPHONE NUMBER 212-775-3538.

I hereby agree to abide by the conditions listed above. I understand that I am responsible to ensure these requirements are met, including all other applicable laws, rules and regulations pertaining to asbestos abatement.

Property Owner's Name: CYNTHIA Ann Roe

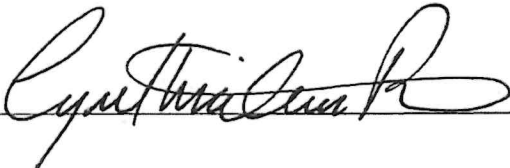
Property Owner's Signature: 

Date: 2 / 3 / 2025

From: Kenneth Marulli kmarulli@greenportvillage.org
Subject: RE: Follow-Up on Building Permit Application
Date: January 31, 2025 at 12:59 PM
To: cindy roe cinroe@gmail.com
Cc: Kevin Stuessi kevin@greenportvillage.org



Cindy,

The inspector reviewed your file and noted the following missing from the application.

3. Contractor MUST PROVIDE: Copy of Suffolk County/Southold Town Contractors or Tradesman License, three (3) Proofs of Insurance; Liability (Acord form, 2M/1M min.), Workers' Compensation (C105.2 form), & Disability (DB 120.1 form). Forms shall show the property owner and property location, and list the Village of Greenport as the additional insured/contract holder. THE CONTRACTORS WORKERS COMP INSURANCE (ATTACHED) HAS EXPIRED AND NEEDS TO HAVE THE VILLAGE OF GREENPORT LISTED AS THE CERTIFICATE HOLDER. IF ELECTRICIAN IS BEING USED, ELECTRICIANS LICENSE AND INSURANCE INFO.

7. Proof of approvals from other agencies & statutory boards having jurisdiction, if applicable (i.e. New York State Department of Environmental Conservation, Village of Greenport, Suffolk County Department of Health, Village of Greenport Zoning Board of Appeals, Village of Greenport Planning Board, Village of Greenport Historic Preservation Commission, Village of Greenport Board of Trustees) PLEASE SUBMIT AN APPLICATION TO THE HPC FOR WINDOW CHANGES. IF POSSIBLE, SUBMIT BEFORE FEB 6 SO THAT IT MAKES THE FEB 7 MEETING. BRING TO MEETING BROCHURE FOR WINDOWS.

8. Owner/Applicant must submit completed Asbestos Certification Form (FORM-AC1) THIS FORM CAN BE FOUND ON THE VILLAGE WEBSITE

Please let me know if you have any questions.

Thank you
Ken

From: cindy roe <cinroe@gmail.com>
Sent: Thursday, January 30, 2025 12:28 PM
To: Kenneth Marulli <kmarulli@greenportvillage.org>
Subject: Re: Follow-Up on Building Permit Application

Thank you for the update.







Unit Spec Report - Large Image

QUOTE NAME: ratsey broad street
 PROJECT NAME: Unassigned Project

QUOTE NUMBER: 7042856

CUSTOMER PO#

TRADE ID

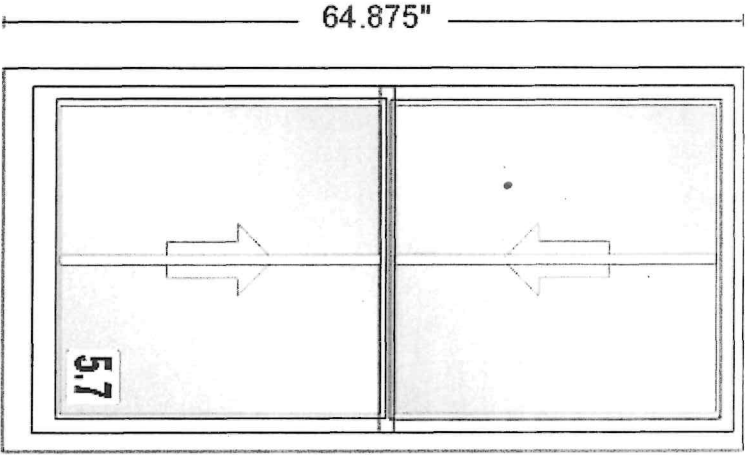

33.625"
 RO - 34.125"

Quote #: 7042856

Print Date: 2/5/2025 5:12:06 PM UTC

All Images Viewed from Exterior

Page 2 of 5

Room: None Assigned

Item	Qty	Operation
100-1	3	AA
RO Size: 34 1/8" x 64 7/8"		
Unit Size: 33 5/8" x 64 7/8"		

Comments:

400 Series Double-Hung, Low-E4, Standard, Grilles: FDL, Specified Equal Light, No Simulated Check Rail, 3/4", White, Pine, Unfinished, 2W1H

Instructions to Manufacturer:

Unit #	U-Factor	SHGC	ENERGY STAR
A1	0.31	0.28	NO

Clear Opening/Unit #	Width	Height	Area (Sq. Ft)
A1	29.8750	27.7500	5.77000

Unit Spec Report - Large Image

QUOTE NAME: ratsey broad street
 PROJECT NAME: Unassigned Project
 QUOTE NUMBER: 7042856

CUSTOMER PO#

TRADE ID

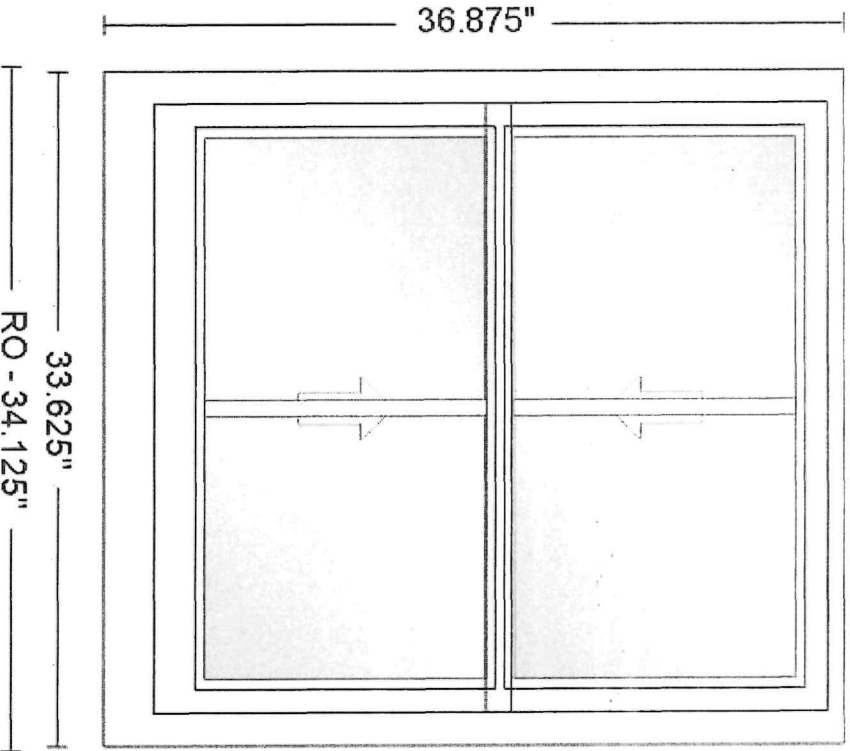

Room: None Assigned

Item	Qty	Operation
200-1	3	AA

RO Size: 34 1/8" x 36 7/8"

Unit Size: 33 5/8" x 36 7/8"

Comments:

400 Series Double-Hung, Low-E4, Standard, Grilles: FDL, Specified Equal Light, No Simulated Check Rail, 3/4", White, Pine, Unfinished, 2W1H

Instructions to Manufacturer:

Unit #	U-Factor	SHGC	ENERGY STAR
A1	0.31	0.28	NO

Clear Opening/Unit #	Width	Height	Area (Sq. Ft)
A1	29.8750	13.7500	2.86000

Unit Spec Report - Large Image

QUOTE NAME: ratsey broad street PROJECT NAME: Unassigned Project QUOTE NUMBER: 7042856 CUSTOMER PO#: TRADE ID:

Frame Major Radius = 18.9035969"
 Frame Minor Radius = 7.903279"

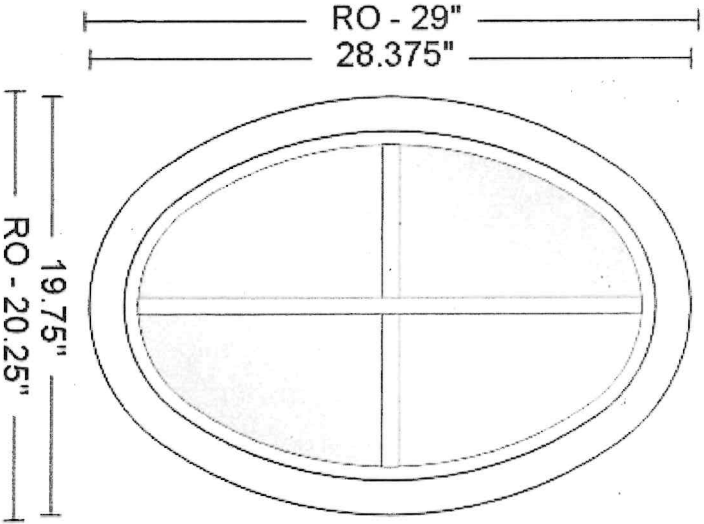

Room: None Assigned

Item	Qty	Operation
300-1	1	Fixed

 RO Size: 20 1/4" x 29"
 Unit Size: 19 3/4" x 28 3/8"

Comments:

400 Series Specialty Oval, Low-E4, Standard, Grilles: FDL, Colonial, Typical, 3/4", White, Pine, Unfinished, 2W2H
Instructions to Manufacturer:

Unit #	U-Factor	SHGC	ENERGY STAR
A1	0.28	0.31	NO

Quote #: 7042856

Print Date: 2/5/2025 5:12:06 PM UTC

All Images Viewed from Exterior

Page 4 of 5

Suffolk County Dept. of
Labor, Licensing & Consumer Affairs

HOME IMPROVEMENT LICENSE



Name

COLIN D RATSEY

Business Name

RATSEY CONSTRUCTION

This certifies that the
bearer is duly licensed
by the County of suffolk

License Number [REDACTED]

Issued: 01/01/1992

Expires: 01/01/2026

Wayne T. Rogers
Commissioner

CERTIFICATE OF WORKERS' COMPENSATION INSURANCE



SCAN TO VALIDATE
AND SUBSCRIBE

***** 133376596
COLIN RATSEY D/B/A
RATSEY CONSTRUCTION
PO BOX [REDACTED]
GREENPORT NY 11944

POLICYHOLDER COLIN RATSEY D/B/A RATSEY CONSTRUCTION PO BOX [REDACTED] GREENPORT NY 11944

CERTIFICATE HOLDER VILLAGE OF GREENPORT 236 THIRD STREET GREENPORT NY 11944

POLICY NUMBER [REDACTED]	CERTIFICATE NUMBER [REDACTED]	POLICY PERIOD 01/09/2025 TO 01/09/2026	DATE 2/1/2025
------------------------------------	---	--	-------------------------

THIS IS TO CERTIFY THAT THE POLICYHOLDER NAMED ABOVE IS INSURED WITH THE NEW YORK STATE INSURANCE FUND UNDER POLICY NO. 1103816-3, COVERING THE ENTIRE OBLIGATION OF THIS POLICYHOLDER FOR WORKERS' COMPENSATION UNDER THE NEW YORK WORKERS' COMPENSATION LAW WITH RESPECT TO ALL OPERATIONS IN THE STATE OF NEW YORK, EXCEPT AS INDICATED BELOW, AND, WITH RESPECT TO OPERATIONS OUTSIDE OF NEW YORK, TO THE POLICYHOLDER'S REGULAR NEW YORK STATE EMPLOYEES ONLY.

IF YOU WISH TO RECEIVE NOTIFICATIONS REGARDING SAID POLICY, INCLUDING ANY NOTIFICATION OF CANCELLATIONS, OR TO VALIDATE THIS CERTIFICATE, VISIT OUR WEBSITE AT [HTTPS://WWW.NYSIF.COM/CERT/CERTVAL.ASP](https://www.nysif.com/cert/certval.asp). THE NEW YORK STATE INSURANCE FUND IS NOT LIABLE IN THE EVENT OF FAILURE TO GIVE SUCH NOTIFICATIONS.

THIS POLICY DOES NOT COVER THE SOLE PROPRIETOR, PARTNERS AND/OR MEMBERS OF A LIMITED LIABILITY COMPANY.

THIS CERTIFICATE IS ISSUED AS A MATTER OF INFORMATION ONLY AND CONFERS NO RIGHTS NOR INSURANCE COVERAGE UPON THE CERTIFICATE HOLDER. THIS CERTIFICATE DOES NOT AMEND, EXTEND OR ALTER THE COVERAGE AFFORDED BY THE POLICY.

NEW YORK STATE INSURANCE FUND

DIRECTOR, INSURANCE FUND UNDERWRITING

VALIDATION NUMBER: 684737938

CERTIFICATE OF WORKERS' COMPENSATION INSURANCE (RENEWED)

***** 475098236
REP ELECTRIC LLC
P O BOX [REDACTED]
MATTITUCK NY 11952



SCAN TO VALIDATE
AND SUBSCRIBE

POLICYHOLDER REP ELECTRIC LLC P O BOX [REDACTED] MATTITUCK NY 11952		CERTIFICATE HOLDER RATSEY CONSTRUCTION PO BOX [REDACTED] GREENPORT NY 11944	
POLICY NUMBER [REDACTED]	CERTIFICATE NUMBER [REDACTED]	POLICY PERIOD 02/09/2024 TO 02/09/2025	DATE 1/30/2025

THIS IS TO CERTIFY THAT THE POLICYHOLDER NAMED ABOVE IS INSURED WITH THE NEW YORK STATE INSURANCE FUND UNDER POLICY NO. 1345981-3, COVERING THE ENTIRE OBLIGATION OF THIS POLICYHOLDER FOR WORKERS' COMPENSATION UNDER THE NEW YORK WORKERS' COMPENSATION LAW WITH RESPECT TO ALL OPERATIONS IN THE STATE OF NEW YORK, EXCEPT AS INDICATED BELOW, AND, WITH RESPECT TO OPERATIONS OUTSIDE OF NEW YORK, TO THE POLICYHOLDER'S REGULAR NEW YORK STATE EMPLOYEES ONLY.

IF YOU WISH TO RECEIVE NOTIFICATIONS REGARDING SAID POLICY, INCLUDING ANY NOTIFICATION OF CANCELLATIONS, OR TO VALIDATE THIS CERTIFICATE, VISIT OUR WEBSITE AT [HTTPS://WWW.NYSIF.COM/CERT/CERTVAL.ASP](https://www.nysif.com/cert/certval.asp). THE NEW YORK STATE INSURANCE FUND IS NOT LIABLE IN THE EVENT OF FAILURE TO GIVE SUCH NOTIFICATIONS.

THIS POLICY DOES NOT COVER THE SOLE PROPRIETOR, PARTNERS AND/OR MEMBERS OF A LIMITED LIABILITY COMPANY.

THIS CERTIFICATE IS ISSUED AS A MATTER OF INFORMATION ONLY AND CONFERS NO RIGHTS NOR INSURANCE COVERAGE UPON THE CERTIFICATE HOLDER. THIS CERTIFICATE DOES NOT AMEND, EXTEND OR ALTER THE COVERAGE AFFORDED BY THE POLICY.

NEW YORK STATE INSURANCE FUND

DIRECTOR, INSURANCE FUND UNDERWRITING

VALIDATION NUMBER: 316367830

- **Hinge Finish:** US10B Oil Rubbed Bronze
- **Sill:** Composite Adjustable
- **Sill Finish:** Mill Finish w Light Cap
- **Lock Option:** None
- **Bore:** Double Lock Bore 2-3/8" Backset
- **Strike Jamb Prep:** Schlage Dexter/Kwikset Scant Prep
- **Weatherstrip Type:** Compression
- **Weatherstrip Color:** Bronze
- **Custom Height Option:** No
- **Kick Plate:** None
- **Door Viewer:** None
- **Sill Cover:** Yes
- **Finish Frame Exterior Color:** Unfinished
- **Finish Frame Interior Color:** Unfinished
- **Rough Opening Width:** 38 1/2"
- **Rough Opening Height:** 82 1/2"
- **Total Unit Width(Includes Exterior Casing):** 37 5/8"
- **Total Unit Height(Includes Exterior Casing):** 82"

Item Total: \$ 1,318.07

Item Quantity Total: \$ 1,318.07

Item: 0002: Ext 36" x 80" F77504G LHI 4 9/16" On-Guard Primed	Location:	Quantity
Fir 36"x80" Single Door		3,010.7

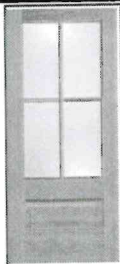

*Back
Fav*

Configuration Options [Hide](#)



- **Product Category:** Exterior Doors
- **Manufacturer:** Reeb - Wood Exterior
- **Product Type:** Exterior
- **Region:** East
- **Product Material:** Nantucket Series Wood Grip Tenon - No Pins
- **Material Type:** Fir
- **Configuration (Units viewed from Exterior):** Single Door
- **Factory Finish Option:** No
- **Slab Width:** 36"
- **Slab Height:** 80"
- **Product Style:** 3/4 Lite
- **Glass Type:** Clear
- **Panel Type:** 1-7/16" Double Hip Raised
- **Grille Type:** 7/8" SDL
- **Insulation:** Low E
- **Model:** F77504G
- **Sticking:** Ovolo
- **Handing:** Left Hand Inswing
- **Frame Material:** On-Guard Primed
- **Jamb Depth:** 4 9/16"
- **Casing/Brickmould Pattern:** None
- **Hinge Type:** Radius Corner Ball Bearing
- **Hinge Brand:** Reeb
- **Hinge Finish:** US10B Oil Rubbed Bronze

- **Sill:** Composite Adjustable
- **Sill Finish:** Mill Finish w Light Cap
- **Lock Option:** None
- **Bore:** Double Lock Bore 2-3/8" Backset
- **Strike Jamb Prep:** Schlage Dexter/Kwikset Scant Prep
- **Weatherstrip Type:** Compression
- **Weatherstrip Color:** Bronze
- **Custom Height Option:** No
- **Kick Plate:** None
- **Mail Slot:** None
- **Sill Cover:** Yes
- **Finish Frame Exterior Color:** Unfinished
- **Finish Frame Interior Color:** Unfinished
- **Rough Opening Width:** 38 1/2"
- **Rough Opening Height:** 82 1/2"
- **Total Unit Width(Includes Exterior Casing):** 37 5/8"
- **Total Unit Height(Includes Exterior Casing):** 82"

Item Total: \$ 3,010.26
Item Quantity Total: \$ 3,010.26

Unit Summary						Hide
Item	Location	Description	Quantity	Unit Price	Total Price	
<u>0001</u>		Ext 36" x 80" F2060 LHI 4 9/16" On-Guard Primed	1	\$ 1,318.07	\$ 1,318.07	
<u>0002</u>		Ext 36" x 80" F77504G LHI 4 9/16" On-Guard Primed	1	\$ 3,010.26	\$ 3,010.26	

SUBMITTED BY: _____
ACCEPTED BY: _____
DATE: _____

SUBTOTAL: \$ 4,328.33
TAXES (%): \$ 0.00
GRAND TOTAL: \$ 4,328.33

Reeb Warranties



Therma-Tru Energy Star Charts



Additional Information:

I understand that this order will be placed according to these specifications and is non-refundable. All products are unfinished unless otherwise specified and should be finished as per the instructions provided by the manufacturer. Images on this quote should be considered a representation of the product and may vary with respect to color, actual finish options and decorative glass privacy ratings. Please verify with sales associate before purchasing. Unless otherwise noted, prices are subject to change without notice, and orders accepted subject to prices in effect at time of shipment. Prices in this catalog apply only to sizes and descriptions listed; any other specifications will be considered special and invoiced as such.